

FLOAT AND THERMOSTATIC STEAM TRAPS UFS32 (For use with universal pipeline connectors)

DESCRIPTION

The UniADCA UFS32 series float and thermostatic (integral air vent) steam traps, completely in stainless steel, are maintenance free and sealed. They are specifically designed to work with low and medium pressure steam and all types of heating and process equipment.

Typical applications include unit heaters, heat exchangers, driers, jacketed vessels and all the applications where continuous drainage is essential.

These traps fit the UCX universal connectors and CTS4U compact stations.

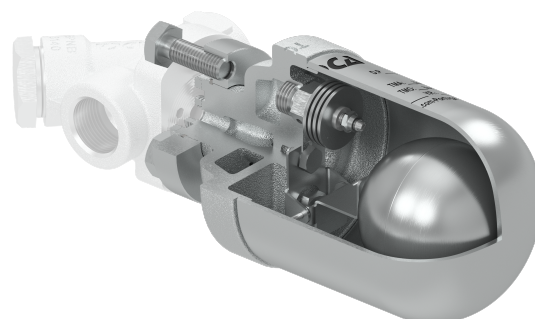

MAIN FEATURES

- Sealed, non-maintainable.
- Two-bolt swivel connector.
- Modulating discharge.
- Discharges condensate at steam temperature.
- Unaffected by sudden or wide load and pressure changes.
- Excellent air discharge (by thermostatic air vent).

USE: Saturated and superheated steam.

AVAILABLE

MODELS: UFS32-4,5, UFS32-10, UFS32-14, UFS32-21 and UFS32-32 – stainless steel.

SIZES: According to the selected pipeline connector.

INSTALLATION: Always in a horizontal plane with the “O” of the TOP inscription perfectly aligned with the vertical axis.
See IMI – Installation and maintenance instructions.

ΔPMX: UFS32-4,5 – 4,5 bar
UFS32-10 – 10 bar
UFS32-14 – 14 bar
UFS32-21 – 21 bar
UFS32-32 – 32 bar

CE MARKING – GROUP 2 (PED – EUROPEAN DIRECTIVE)

CLASS 300	CATEGORY
All sizes	SEP

BODY LIMITING CONDITIONS *

CLASS 300 ALLOWABLE PRESSURE	RELATED TEMPERATURE
47,8 bar	-10 / 50 °C
40,9 bar	100 °C
34,4 bar	200 °C
30,6 bar	300 °C
28,6 bar	400 °C

PMO – Maximum operating pressure: 32 bar.
TMO – Maximum operating temperature: 245 °C.

* According to EN 1759-1:2004.

Remark: The pipeline connector may restrict the operating conditions to a lower rating.

FLOW RATE CAPACITY (kg/h)

MODEL	DIFFERENTIAL PRESSURE (bar)															
	0,5	1	1,5	2	3	4,5	6	7	8	9	10	12	14	16	21	32
UFS32-4,5	160	220	250	295	330	385	–	–	–	–	–	–	–	–	–	–
UFS32-10	110	150	175	190	220	275	300	325	340	355	370	–	–	–	–	–
UFS32-14	80	110	130	150	175	200	230	250	270	285	300	315	335	–	–	–
UFS32-21	65	85	100	120	140	170	190	200	215	230	245	265	280	300	340	–
UFS32-32	40	55	65	75	90	110	130	140	150	160	170	180	190	200	235	285

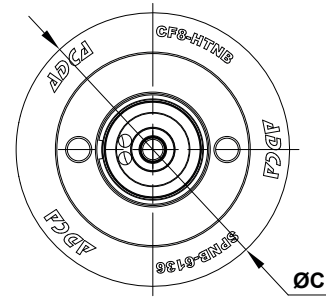
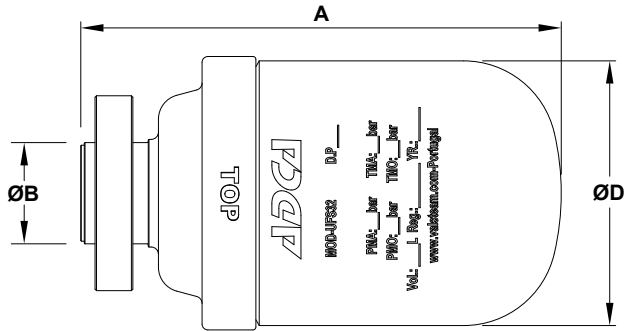

DIMENSIONS (mm)

MODEL	A	ØB	ØC	ØD	WEIGHT (kg)
UFS32	164	35	67	94	2,1

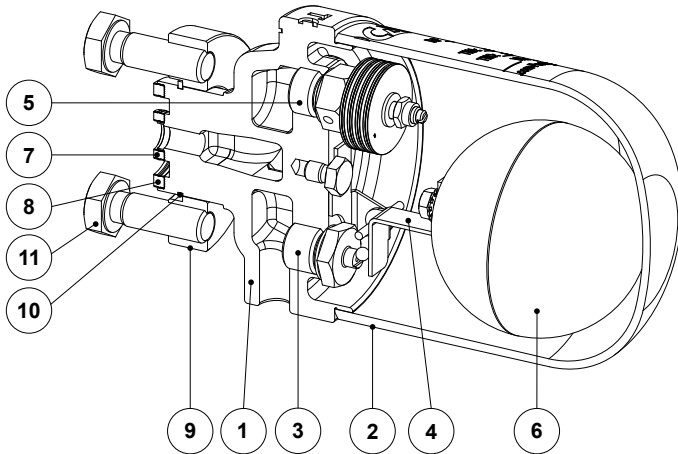

MATERIALS

POS. No.	DESCRIPTION	MATERIAL
1	Body	A351 CF8 / 1.4308
2	Cover	AISI 304 / 1.4301
3	Valve seat	Hardened stainless steel
4	Valve	Hardened stainless steel
5	Air vent	Stainless steel; Bimetal
6	Float	AISI 301 / 1.4301
7	* Inlet gasket	Stainless steel / Graphite
8	* Outlet gasket	Stainless steel / Graphite
9	Flange	AISI 316 / 1.4401
10	Retainer ring	Steel
11	Bolt	ASTM A193 Gr. B7

* Available spare parts.

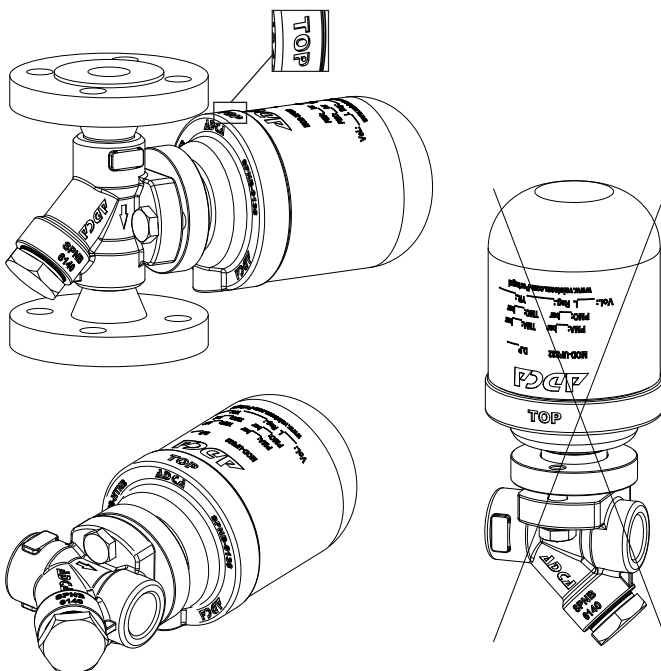

*UFS32 steam trap connected to a UCX41
universal pipeline connector*

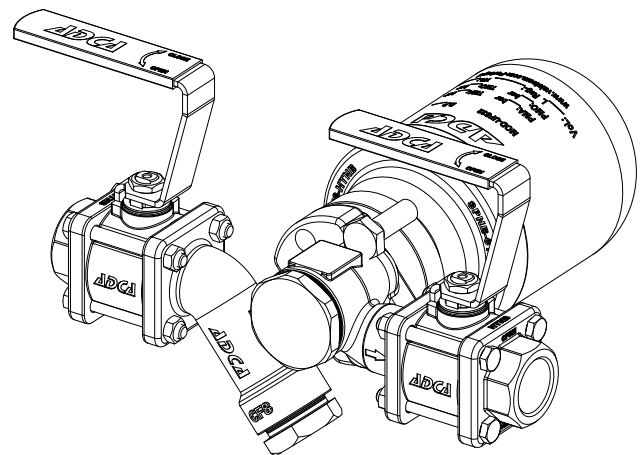

*UFS32 steam trap connected to a CTS4U
universal compact trapping station*